

AP1000® Full-scope Simulator

Background

The AP1000® full-scope simulator provides the capability to train plant operators in a replica control room that represents the control consoles, control panels and displays in the plant control rooms. The plant dynamic behavior and process control is simulated via a plant dynamic model executing in a multiprocessor plant model computer running the Windows® operating system. The control room human system interface (HSI) is stimulated, thereby maintaining high-fidelity operator interaction, while the control systems are translated to support plant dynamics on a single computer platform.

Description

The simulator architecture includes the Ovation® and Common Q equipment necessary to represent the data display and operator input capabilities present on the displays and consoles in the plant control room. Digital input/output (I/O) related to devices on the control consoles pass to and from the plant model computer through simulator I/O devices. The plant model computer executes the plant dynamic model

and also executes translated versions of the Ovation and Advant® Controller (AC160) instrumentation and control (I&C) application software. The instructor station system provides the instructor with the ability to control the operation of the simulation.

The plant model computer communicates with the Ovation data highway (real-time data network) via Ovation Sim Stations and with Common Q flat panel displays via an Ethernet link. The Ovation equipment communicates through the Ovation data highway, which is implemented as an Ethernet network. Data on the network is then available to the computerized procedure station, the historian/report server, the application server, the system server and to Ovation operator stations. These devices provide functions to the simulator that are analogous to the functions their counterparts provide on the actual plant network. The simulator also includes a number of hardcopy devices for the control room and for the plant model computer.

Benefits

- Provides state-of-the-art open system architectures for both hardware and software
- Reduces the software effort required to emulate the I&C system, using automated translation tools



AP1000 control room

AP1000 Simulator Architecture

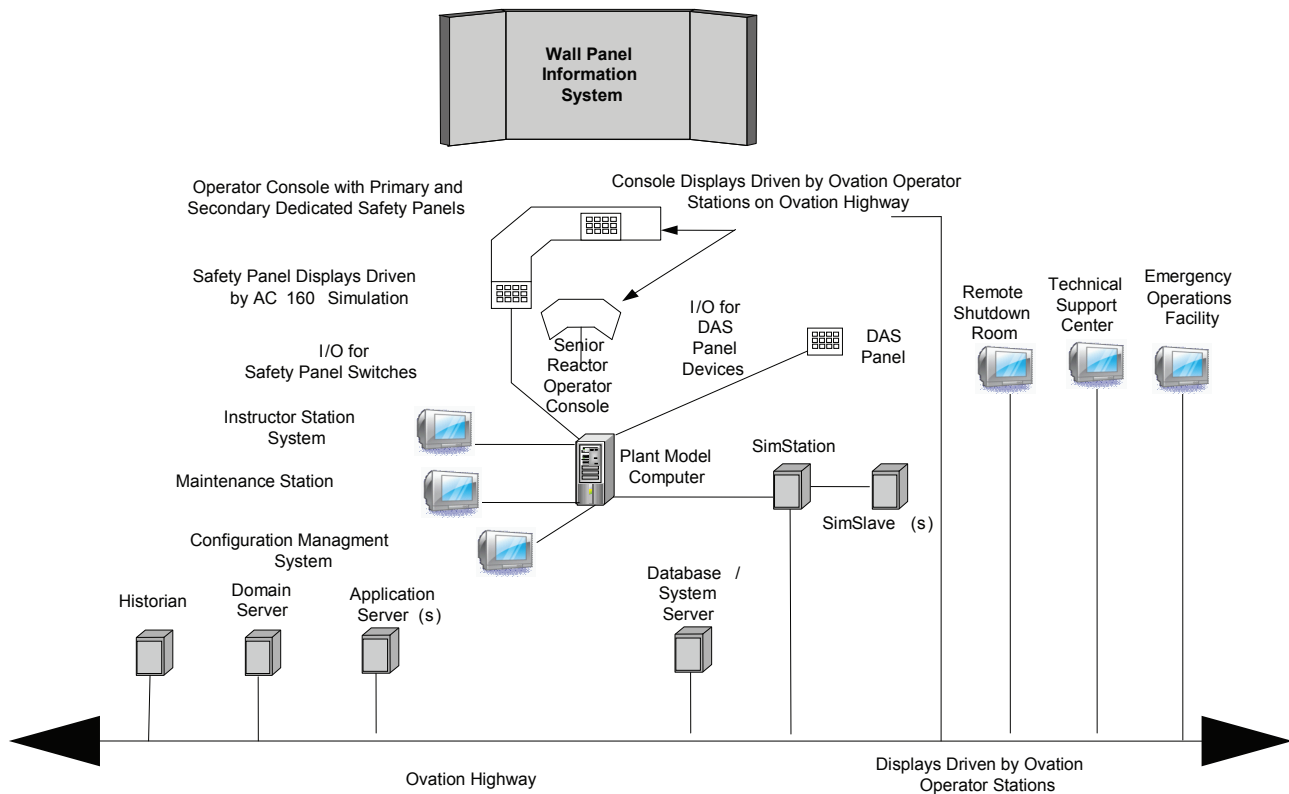

AP1000 simulator architecture

- Controls maintenance costs associated with simulator upgrades: software upgrade cost is minimized, and hardware modifications can be done in parallel with plant upgrades
- Provides high-fidelity simulation by re-using actual I&C system components and software
- Provides absolute HSI software re-usability, identical to plant's operator interface in both design intent and unintended features
- Allows open- or closed-loop testing of actual control/information system software, independent of the target hardware
- Allows I&C application software to be largely reused from the system application, saving time and money by application testing once for both the plant and simulator stimulated systems, and reducing scope testing of the translated systems
- Trains operators on all plant procedures from startup to shutdown, including operations at reduced reactor coolant inventory, with the simulator operating continuously through these modes of plant operation
- Has extensive capabilities for simulating malfunctions, component failures, local operator actions and control overrides, allowing operators to be trained in a full spectrum of abnormal plant conditions

AP1000 is a trademark or registered trademark of Westinghouse Electric Company LLC in the United States and may be registered in other countries throughout the world. All rights reserved. Unauthorized use is strictly prohibited.

Windows is a trademark or registered trademark of Microsoft. Other names may be trademarks of their respective owners.

Ovation is a trademark or registered trademark of Emerson Process Management. Other names may be trademarks of their respective owners.

Advant is a trademark or registered trademark of ABB Process Automation Corporation. Other names may be trademarks of their respective owners.

Westinghouse Electric Company
1000 Westinghouse Drive
Cranberry Township, PA 16066

www.westinghousenuclear.com